



P4 Track and Wheel Standards

Issue 2
December 1998

Russ Elliott

Acknowledgements The P4 standard track and wheel dimensions given in this section of the Digest were produced by the members of the Model Railway Study Group (MRSNG) in the mid-1960s. The railhead sections and tyre contour drawings are based, with permission, on the original Protofour track and wheel drawings made by Joe Brook Smith.

Introduction

This revision in the presentation of the P4 track and wheel standards has been produced:

- to provide information for existing and potential manufacturers who wish to produce components to P4 standards (the original presentation of the standards having been drawn up with only one manufacturer in mind);
- to provide information to modellers on the derivation, purpose and operation of the standards.

It is emphasised that much of the material given in this section of the Digest, particularly that shown on figure 1, is directed primarily at existing and prospective manufacturers of P4 components. For the modeller, the available construction gauges and rail components should result in correctly constructed P4 track without the need to measure anything or the need to refer to the standards, but it is hoped that the information regarding the derivation and operation of the P4 standards will give both modellers and manufacturers some of the founding principles behind the standards, and will therefore be of interest.

In the derivation of the standards, manufacturing tolerances, including the effect of the possible build-up of tolerances on other dimensions, have been taken into account, but the Society welcomes any comments from manufacturers in the application of the standards.

The P4 recommended track and wheel standards are given in table 1, and are conditional on the use of the railhead contour(s) and tyre profile shown in figure 1.

Annexes to this section of the Digest contain information on:

- ◆ recommended dimensions at turnout switches;
- ◆ use of gauge widening;
- ◆ use of 4mm scale equivalent dimensions;
- ◆ prototype track and wheel dimensions (for 4'8½" gauge);
- ◆ technical derivation of P4 track and wheel standards.

NOTE. With the exception of figure 1, the drawings are not to scale.

General comments on P4 standards

Some members, especially new ones, become rather concerned at the prospect of having to work to two places of decimals of a millimetre. The Society would like to point out the following:

- 1 Any measurement is not necessarily less exact even though it is not expressed to two places of decimals. The 'OO' and 'HO' gauge of 16.5mm should be exactly that, so is no more or less precise than the P4 gauge of 18.83mm.
- 2 The construction gauges ensure that you get the dimensions correct when you are constructing track without the need to measure anything; the wheels supplied already conform to P4 standard dimensions, although it is recommended that the wheel back-to-back dimension (BB) should be checked for all wheelsets.
- 3 The prototype dimensions from which the P4 values were calculated are only nominal, as continued wear on track and wheels means their profiles soon differ from the standards conceived. The same wear is unlikely to take place on your layout but, in extreme cases, although you may have started with the correct dimensions, your wheels and track may deviate from them with continued use.
- 4 It is not unusual to hear or read remarks to the effect that there is nothing inherently better to be gained by using a gauge of 18.83mm (or the equivalents in the cases of 5'3" and 7'0¼" prototype gauges) for 4mm scale modelling. This is, in fact, a part truth, but applicable only to plain track. The important thing to remember is, when using components to P4 standards, you can be sure, in those respects that matter, all such components are correctly designed to give optimum results notionally on plain track but also through all pointwork, however complex. The same results could be, and occasionally are, achieved in EM and OO by modellers with sufficient skill to modify the parts they buy to the same consistency and accuracy as is built into components complying with P4 standards.

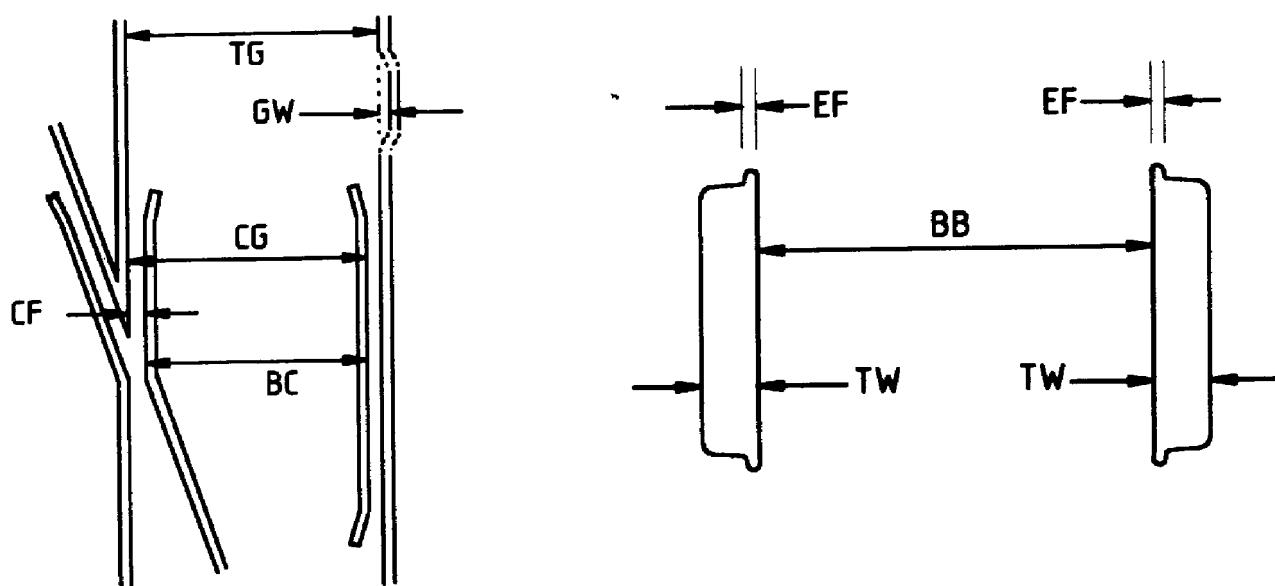

Table 1 Recommended P4 track and wheel standards, 4'8½", 5'3" and 7'0¼" nominal prototype gauges

Dimension	4'8½" gauge		5'3" gauge		7'0¼" gauge	
	min.	max.	min.	max.	min.	max.
TG Track gauge	18.83*	see GW	21.00*	see GW	28.08*	see GW
GW Gauge widening (at 528mm radius)	-	0.22	-	0.22	-	0.22
CG Check gauge	18.15*	18.20	20.32*	20.37	27.40*	27.45
CF Crossing flangeway (see note 2)	0.65	0.68*	0.65	0.68*	0.65	0.68*
BC Between checks	-	17.47*	-	19.64*	-	26.72*
EF Effective flange thickness (see note 1)	0.35	0.40	0.35	0.40	0.35	0.40
BB Wheel back-to- back	17.67*	17.75 (see note 3)	19.84*	19.92	26.92*	27.00
TW Tyre width (see notes 4 and 5)	1.85	2.00	1.85	2.00	1.85	2.00

All P4 dimensions are in millimetres

* These dimensions are controlled by construction gauges.

NOTES:

1 The above P4 dimensions are conditional on the use of the tyre profile and railhead contour(s) shown in figure 1. The EF dimension replaces the complex actual dimensions of the flange in the compilation of the P4 track standards, and is included above only for the sake of indicating the EF limits that are expected to be achieved in the tyre profile - see the annex on 'Technical derivation of P4 track and wheel standards'.

2 0.68mm is the preferred dimension for CF.

3 The BB dimension may under certain circumstances be extended by the modeller to the 4mm scale equivalent dimension. See 'Use of 4mm scale equivalent dimensions'. For the P4 limits given above, it is recommended that any BB construction gauge be manufactured to the upper end of the specified range.

4 The 2.00mm maximum TW limit does not affect the correct interrelationship of P4 standards, but is recommended in order to keep the overall width of the wheelset to a reasonable maximum.

5 It is recommended that the finished tyre width within a production batch does not vary by more than 0.05mm.

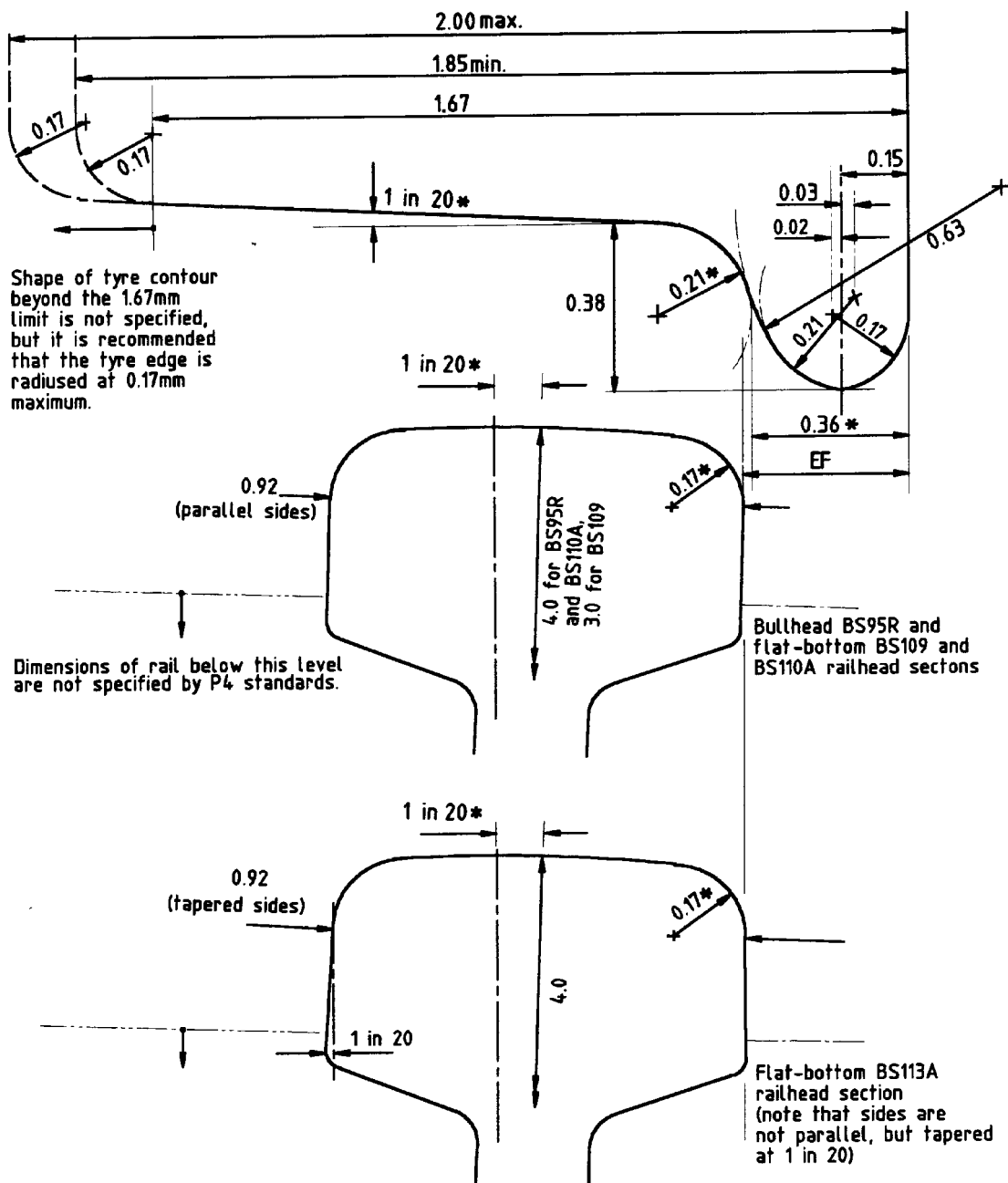

NOTES:

- 1 Any deviation from the dimensions marked * will alter the effective flange dimension (EF) from the P4 standard. Deviation from any flange or railhead dimension may adversely affect performance.
- 2 The tyre profile is based on BS 276 contour A.
- 3 All dimensions are in millimetres.
- 4 The tolerances on any contour tools used for the production of tyres or rail are recommended to be:
 - ± 0.0125mm, for all flange dimensions (with the exception of the tyre front edge radius);
 - ± 0.025mm, for railhead dimensions.

Figure 1 P4 tyre profile and railhead contours

Annexes

Recommended dimensions at turnout switches

The following dimensions should be observed at turnout switches.

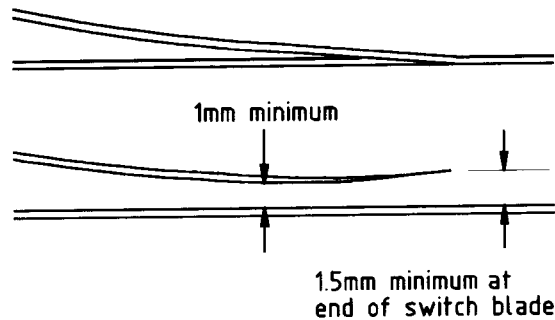

Use of gauge widening

Gauge widening should not be applied to any sections of pointwork where CG, CF or BC dimensions are specified.

Where applied to non-pointwork curves, prototype gauge widening at 10 chains radius is 0.25", at 7 chains radius is 0.5", and at 5½ chains radius is 0.75" maximum. (In 4mm scale, 1 chain is equal to 264mm, or approximately 10½".) In P4, where BB_{max} is less than the 4mm scale equivalent, and where adequate sideplay can usually be given to inner axles, gauge widening should not be necessary unless using long-wheelbase stock around sharp curves.

Where required, check rails should be set from the outer rail of a curve, using a CG gauge (in the same manner as the CG gauge is used in turnout construction), and gauge widening should be applied only to the inner running rail if wheelsets are still found to be binding.

Use of 4mm scale equivalent dimensions (4'8½" gauge)

For a number of reasons, some of the P4 recommended dimensions are not exact scaled-down equivalents of the prototype dimensions, and most modellers use the recommended P4 dimensions as published, with wheels, track components and construction gauges conforming to these standard dimensions. The exact scaled-down dimensions differing from the P4 recommended values are:

CG	Check gauge	18.25mm
CF	Crossing flangeway	0.58mm
BC	Between checks	17.67mm
BB	Wheel back-to-back	17.87mm

Wheelsets built accurately to P4 dimensions will not run through exact-scale pointwork, but 4mm scale equivalent wheelsets (with the increased BB) will run through pointwork built to P4 recommended dimensions. It is emphasised that the Society recommends only the P4 dimensions, whilst recognising that more experienced modellers may choose to use the 4mm scale equivalent dimensions.

The P4 recommended BB dimension is specified in order to allow vehicles with a rigid wheelbase of more than 2 axles to negotiate turnouts and curves appreciably sharper than the prototype equivalents. The 4mm scale equivalent dimensions are used by some modellers to:

- ♦ reduce sideplay between wheels and track;
- ♦ improve the functioning of check rails in obtuse ('K') crossings and to improve the running characteristics of wheelsets through certain configurations of turnouts.

The use of the 4mm scale equivalent BB dimension may be found to be beneficial for all 4-wheeled vehicles, and for vehicles of greater than 4 wheels where adequate sideplay can be introduced on the inner axle(s). In this sense, the 4mm scale equivalent BB dimension should not be regarded as incompatible with other P4 recommended values, since, as stated previously, the 4mm scale equivalent BB wheelsets will run through pointwork conforming to P4 dimensions. It should however be noted that the 4mm scale equivalent BB may result in the overall wheelset width exceeding very slightly the nominal prototype equivalent maximum of approximately 21.7mm; Society compensation components are designed to cater for this very marginal difference.

In practice, the only difference required to implement the 4mm scale equivalent dimensions is a slight adjustment of the BB value and crossing flangeway (CF) setting.

Prototype track and wheel dimensions (for 4'8½" gauge)

For information, and comparison with the P4 values, the prototype 4'8½" track and wheel dimensions and their 4mm scale equivalents are given in the following table.

Prototype track and wheel dimensions (for 4'8½" gauge)		
Dimension	Prototype	4mm scale equivalent
TG Track gauge	4'8½"	18.83mm
GW Gauge widening	¾" maximum at 5½ chains radius	0.25mm
CG Check gauge	4'6¾"	18.25mm
CF Crossing flangeway	1¾"	0.58mm
BC Between checks	4'5"	17.67mm
EF Effective flange thickness	1 ⅛"	0.38mm
BB Wheel back-to-back	4'5 ⅒" minimum 4'5 ⅓" maximum	17.87mm 17.89mm
TW Tyre width	5" minimum, 6½" maximum (see note 1)	1.67mm
Tyre contour	Various (see note 2)	2.17mm

NOTES:

1 Some early wagon tyre widths were specified as 5", but wagon tyres are generally 5 ⅜" or 5½" wide, coach tyres are 5½" wide, and loco tyres are towards the upper end of the specified range.

2 Prototype tyre contours vary, but the BS 276 contour A, first published in 1927 but in effective use some time before that, was a commonly-used profile. Developments during the 1960s have lead increasingly toward the adoption of more refined 'single point contact' profiles.

3 Imperial values for prototype dimensions are used in the above.

Technical derivation of P4 track and wheel standards

The most important single factor in ensuring reliable P4 operation is the maintenance of the correct tyre and railhead contours, and the successful use of the P4 track and wheel standards is conditional on the use of the scaled-down equivalents of these contours, as given in figure 1. From these contours is derived the effective flange thickness dimension (EF), which is the distance between the rail running face and the back face of the wheel flange when the front of the flange is in contact with the rail, i.e. when the flange root radius meets the radius at the side of the railhead; any further movement of the wheel toward the rail will cause the wheel to ride up and loose contact at the tread. The EF dimension replaces the complex actual dimensions of the flange in the compilation of the P4 track standards. The P4 value for EF is specified as 0.35mm minimum to 0.40mm maximum, and is equivalent to the corresponding nominal 1.125" EF of the prototype flange dimensions.

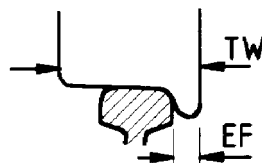

Tyre and railhead contours as per figure 1

Many of the dimensions given in table 1 are interrelated, and the following conditions, whose basis applies equally to the prototype, have been used in the formulation of P4 standards.

Key to diagrams

- V = crossing vee
- W = wing rail
- C = check rail
- R = running/stock rail

NOTE. The following diagrams are representational, and are not to scale.

$$1 \quad BB_{\max} + 2EF_{\max} + \text{clearance} \leq TG_{\min}$$

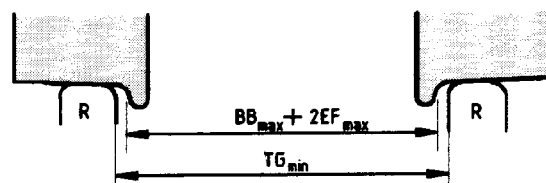

This condition allows wheelsets to roll freely along the running rails, whether through turnouts or on plain track. (See Note overleaf)

NOTE. The clearance in the above condition represents the sideplay of the wheelset on the track gauge. In the formulation of P4 standards, a nominal clearance value of 0.25mm was adopted, in order to take account of the less than prototype equivalent track radii used in models, and the accuracy to which the wheelset BB could reasonably be expected to be maintained within the specified maximum. In practice, experience has shown that 0.25mm may be a little too generous, and a clearance of 0.15mm may be regarded as the minimum permissible. See also the notes on 'Use of gauge widening' and 'Use of 4mm scale equivalent dimensions'.

$$2 \quad CG_{\min} \geq BB_{\max} + EF_{\max}$$



The minimum check gauge must not be less than the maximum wheel back-to-back plus one maximum effective flange: this condition represents the checking function, i.e. that the check rail, in making contact with the rear face of the flange of wheel B, will ensure that wheel A cannot take the wrong route through the crossing vee when approaching the vee from the toe of the turnout. (In practice, because of the shape of the root of the flange, the likelihood of wheel A taking the wrong route increases only as BB_{\max} approaches the value of CG_{\min} .)

$$3 \quad TG_{\min} - CF_{\max} \geq CG_{\min}$$

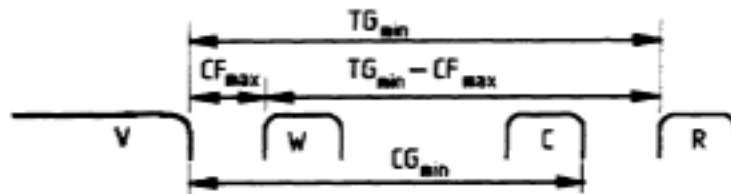

The minimum track gauge minus the maximum crossing flangeway must not be less than the minimum check gauge: this condition is a counterpart of condition 2, and ensures that the wing rail can act with a checking function to prevent the flange of wheel B from taking the wrong route where the running rail R is or is about to become itself a part of another vee or crossing.

NOTE. Whilst the above condition is necessary for the reason stated, it is obviously undesirable for the rear face of the flange of wheel A to strike the wing rail too abruptly when approaching the vee from the toe of the turnout. The necessity for a wing rail to act with a checking function in the above circumstances, e.g. in a three-way turnout (where there is a discontinuity in the adjacent running rail) has therefore to be balanced against the desirability of avoiding wing rail checking in other situations, e.g. on the outside road of a curved turnout (where wheel B is naturally hard up against the running rail). This dilemma is shared by the prototype, and care needs to be exercised where specialised pointwork is being constructed. The use of the 4mm scale equivalent BB dimension will alleviate the problem.

4 $TW_{min} \geq 2CF_{max}$

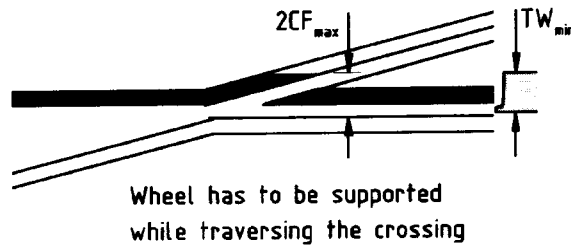

Twice the maximum crossing flangeway must not exceed the minimum tyre width: this condition prevents wheel drop at the crossing nose.

NOTE. The P4 value specified for TW_{min} exceeds twice the CF_{max} value by a comfortable margin, to ensure that:

- ♦ the wheel is fully supported both before and after the actual point of the crossing vee nose; and
- ♦ an adequate proportion of the specified part of the wheel tread is in contact with the railhead on sharply-curved track.

5 $CG_{max} - CF_{min} + \text{clearance} \leq BB_{min}$

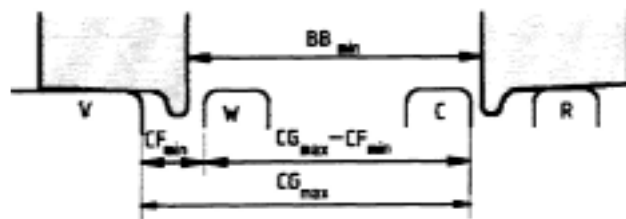

This condition ensures that there is adequate clearance between the inner faces of the wheelset flanges and the distance over the outer faces of the wing and check rail pair. Since $BC_{max} = CG_{max} - CF_{min}$, the above condition can alternatively be expressed as $BC_{max} + \text{clearance} \leq BB_{min}$.

NOTE. The clearance in the above condition represents the sideplay between the inner faces of the wheelset and the width over the outer faces of the check and wing rail pair. In the formulation of P4 standards, a nominal clearance value of 0.17mm was adopted, to take into account the less than prototype equivalent track radii used in models, and the accuracy to which the wheelset BB could reasonably be expected to be maintained within the specified minimum.

6 $EF_{max} + \text{clearance} \leq CF_{min}$

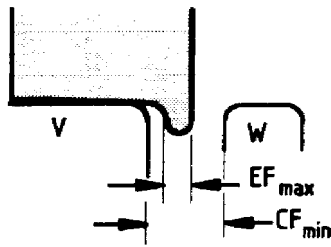

This condition ensures that the flange can pass freely through the crossing flangeway.

7 Although it does not affect the correct interrelationship of P4 track dimensions, a value of 2.00mm is recommended for TW_{max} in order to keep the overall wheelset width from exceeding the prototype equivalent (approximately 21.7mm, in the case of 4'8½" prototype gauge).